

# A FUZZY GOAL PROGRAMMING METHOD TO SOLVE CONGESTION MANAGEMENT PROBLEM USING GENETIC ALGORITHM

Papun Biswas<sup>1</sup> and Bijay Baran Pal<sup>2\*</sup>

<sup>1</sup> Department of Electrical Engineering, JIS College of Engineering, West Bengal, India

<sup>2</sup> Department of Mathematics, University of Kalyani, West Bengal, India

Received: 25 January 2019;

Accepted: 25 April 2019;

Available online: 27 April 2019.

*Original scientific paper*

**Abstract:** *The objective of this work is to present a priority-based fuzzy goal programming (FGP) method for solving the congestion management (CM) problem in electric power transmission lines by employing genetic algorithm (GA). To formulate the model for this problem, membership functions which are associated with the fuzzy model goals are converted into membership goals by assigning highest membership value (unity) as goal level and adding under- and over-deviational variables to each of them. In solution process, a GA computational scheme is addressed within the framework of FGP model to achieve aspired goal levels of goals according to their priorities in imprecise environment. The standard IEEE 30-Bus 6-Generator test system is taken as a case example to show the effectiveness of the approach. A comparison of model solution is also compared with solution of another approach studied previously.*

**Keywords:** *Congestion Management; Fuzzy Goal Programming; Genetic Algorithm; Membership Function; Overload Alleviation; Particle Swarm Optimization*

## 1. Introduction

Congestion in thermal power supply system in Bhattacharya et al. (2012) refers to overloading situation in transmission lines when thermal bounds and line capacities of the power supply system are violated in Chung et al. (2015). Congestion actually occurs when power flow in a transmission line is higher than the flow allowed by operating reliability limits in Nappu and Arief (2016). As such, congestion in power system would have to be rectified as and when needed to ensure system security. Further, a lack of paying proper attention to congestion of the system may lead to widespread blackouts which give birth to negative impact to social and economic

\* Corresponding author.

E-mail addresses: [papunbiswas@ieee.org](mailto:papunbiswas@ieee.org) (P. Biswas), [bbpal18@hotmail.com](mailto:bbpal18@hotmail.com) (B.B. Pal)

A fuzzy goal programming method to solve congestion management problem using genetic... perspectives. Therefore, congestion management in Emami and Sadri (2012) appears as one the key issues to maintain security and reliability of transmission network.

The mathematical programming method for estimating voltage dropping and line loading for out of service of each network element was first introduced in El-Abiad and Stagg (1962) in 1962. Then, different classical optimization methods based on load flow were studied for CM in Manandur and Berg (1978) and Medicherla et al. (1979) in the past century. The decomposition of spot prices to reveal congestion cost component in a pool model was presented in Finney et al. (1997). The DC-optimal power flow (DC-OPF) based approach to compute congestion cost was also propounded by Singh et al. (1998). The real-time operational environment based CM was studied in Fang and David (1999) and Wang and Song (2000) in last two decades. An optimal dispatch with the consideration of dynamic security constraints for CM was discussed in Singh and David (2000). Rau (2000) presented the AC-OPF driven approach to CM along with congestion cost allocation. Then, an effective model to location of unified power flow controller (UPFC) for CM was deeply studied in Verma et al. (2001). The use of *Thyristor-Controlled Series Compensation (TCSC)* to reduce congestion cost is also presented in Lee (2002). To manage congestion, a minimum load curtailment problem was proposed in Rodrigues and Da Silva (2003). An OPF model with multiplicity of objectives and a set of voltage security constraints was also discussed in Milano et al. (2003) with regard to avoiding congestion through the use of location marginal price. The use of rescheduling of generation and load with voltage security constraints for CM was also discussed in Yamin and Shahidepour (2003). An efficient CM approach using real and reactive power rescheduling via optimal allocation of reactive power resources was proposed in Kumar et al. (2004). A simple cost effective model for generation rescheduling and load shedding was also studied in Talukdar et al. (2005) in the past.

The heuristic methods in Hazra and Sinha (2007), Dutta and Singh (2008), Balaraman and Kamaraj (2010) for global optimizations have been made successfully to solve CM problems in the recent past. Hazra and Sinha (2009) put forth an efficient approach based on fuzzy estimation for identifying collapse sequences to reach the optimal solution of a CM problem. Fuzzily described adaptive bacterial foraging algorithm and gravitational search method have also been studied in Venkaiah and Kumar (2011) and Kumar et al. (2013) previously.

To overcome the various drawbacks associated with the previous approaches concerning CM in thermal power supply system, a *priority-based* FGP method for multiobjective decision making (MODM) is addressed in this paper to model CM problem and a GA computational scheme is adapted to reach decision in imprecise premises. In model formulation, fuzzy representations of different objectives are considered for minimization of overload alleviation and operation cost subject to various constraints associated with the problem. The experimental test on standard IEEE 6-Generator 30-bus system is made to expound the effective use of the method. The solution is also compared with solution achieved by using Particle Swarm Optimization (PSO) technique in Hazra and Sinha (2007) is performed to present superiority of the proposed method.

Now, FGP model formulation of a MODM problem is discussed in the section 2.

## 2. FGP problem formulation

In fuzzy environment, objectives are generally described fuzzily, whereas structural resource constraints may be fuzzy or crisp and that depends on how the model parameters are involved there in the decision situation.

In line with the work of Dubois (1987), the generic form of a Fuzzy Programming (FP) problem can be exhibited as follows.

Find  $X$  for:

$$F_k(X) \begin{cases} \gtrsim \\ \lesssim \end{cases} g_k;$$

Subject to:

$$X \in S = \begin{cases} \leq \\ = \\ \geq \end{cases} b, \{X \in R^n; b^T \in R^m\} \tag{1}$$

$$X^L \leq X \leq X^U;$$

$$X \geq 0$$

where  $x$  is a vector of decision variables,  $g_k$  be the imprecise goal level of  $k$ th objective  $F_k(X)$ ,  $k = 1, 2, \dots, K$ ,  $\gtrsim$  and  $\lesssim$  indicate fuzziness of  $\geq$  and  $\leq$  restrictions, respectively, and where  $A$  is a real matrix and  $b$  is a constant vector and  $T$  means transposition,  $X^L$  and  $X^U$  denote the vectors of lower- and upper-limits, respectively, of the vector  $x$ , and where  $L$  and  $U$  indicate lower and upper, respectively. Also, it is assumed that the feasible region  $S (\neq \varnothing)$  is bounded.

Now, characterization of fuzzy goals is by associated membership functions concerned with measuring degree of achievement of each of them in a decision making horizon.

### 2.1. Characterization of membership function

Let  $t_{\ell k}$  and  $t_{uk}$  be lower- and upper-tolerance ranges, respectively, regarding achievement of aspired level  $g_k$  of  $k$ th fuzzy goal.

Then, membership function, say  $\mu_k(X)$ , associated with  $F_k(X)$  can be characterized as follows.

For  $\gtrsim$  type of constraint,  $\mu_k(X)$  appear as in Zimmermann (1987):

$$\mu_k(X) = \begin{cases} 1 & \text{when } F_k(X) \geq g_k, \\ \frac{F_k(X) - (g_k - t_{\ell k})}{t_{\ell k}} & \text{if } g_k - t_{\ell k} \leq F_k(X) < g_k, \\ 0 & \text{when } F_k(X) < g_k - t_{\ell k}, \end{cases} \tag{2}$$

where  $(g_k - t_{\ell k})$  denotes the lower-tolerance limit to achieve the stated fuzzy goal.

Further, for  $\lesssim$  type of constraint,  $\mu_k(X)$  can be presented as:

A fuzzy goal programming method to solve congestion management problem using genetic...

$$\mu_k(X) = \begin{cases} 1 & \text{if } F_k(X) \leq g_k, \\ \frac{(g_k + t_{uk}) - F_k(X)}{t_{uk}} & \text{if } g_k < F_k(X) \leq g_k + t_{uk}, \\ 0 & \text{if } F_k(X) > g_k + t_{uk}, \end{cases} \quad (3)$$

where  $(g_k + t_{uk})$  denotes the upper-tolerance limit to achieve the stated fuzzy goal.

The membership functions in (2) and (3) can be graphically depicted as in Figure 1 and Figure 2, respectively.

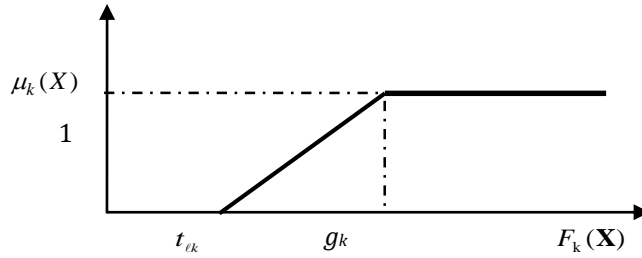

**Figure 1.** Represented Graph of the membership function in (2)

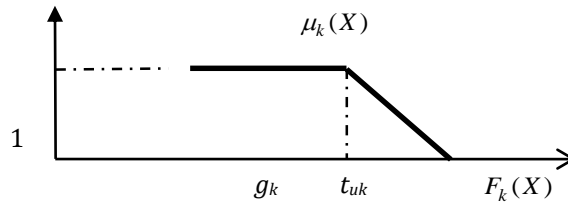

**Figure 2.** Graph of the membership function in (3)

The formulation of an FGP model under a *pre-emptive* priority structure by defining membership goals is described in section 2.2.

## 2.2. FGP model

Since in a MODM context, various conflicting goals are dealt for achieving the aspired levels, *priority-based* FGP is adopted by Pal and Chakraborti (2013) for formulating the model of the problem. In *priority-based* FGP, priorities are assigned to goals according to importance of achieving goal levels, where a set of goals which seems equally important for their goal achievements are included at a same priority level and numerical weights are introduced there according to relative weights of importance to achieve goal levels.

The generic form of a *priority-based* FGP model can be presented as follows.

Find so  $X(x_1, x_2, \dots, x_n)$  as to :

Minimize  $Z = [P_1(d^-), P_2(d^-), \dots, P_r(d^-), \dots, P_R(d^-)]$

and satisfy (4)

$$\frac{F_k(X) - (g_k - t_{lk})}{t_{lk}} + d_k^- - d_k^+ = 1$$

$$\frac{(g_k + t_{uk}) - F_k(X)}{t_{uk}} + d_k^- - d_k^+ = 1$$

subject to the given constraints set as described in (1).

Here  $d_k^-, d_k^+ \geq 0$ ,  $d_k^- d_k^+ = 0$ ,  $k = 1, 2, \dots, K$ , are under and over-deviational variables introduced to  $k$ th goal, and where  $Z$  represents the vector of  $R$  priority achievement function.  $P_r(d^-)$  is a linear function of vector of weighted under-deviational variables, and  $P_r(d^-)$  is of the form:

$$P_r(d^-) = \sum_{k \in K} w_{rk}^- d_{rk}^-; \quad k = \{1, 2, \dots, K\} \tag{5}$$

where  $d_{rk}^-$  is renamed for  $d_k^-$  to represent it at  $r$ th priority level,  $w_{rk}^- (> 0)$  is the numerical weight associated with  $d_{rk}^-$  and it is the weight of importance of achieving  $k$ th goal level relative to others which are grouped together at  $r$ th priority level and where  $w_{rk}^-$  values are determined in Pal et al. (2003) as:

$$w_{rk}^- = \begin{cases} \frac{1}{(t_{lk})_r} \\ \frac{1}{(t_{uk})_r} \end{cases} \tag{6}$$

for  $\mu_k(X)$  in (2) and (3), respectively, where  $(t_{lk})_r$  and  $(t_{uk})_r$  are used to present  $t_{lk}$  and  $t_{uk}$ , respectively, at  $r$ th priority level. Also, the relationship among the priorities is  $P_1 \gg P_2 \gg \dots \gg P_r \gg \dots \gg P_R$ , where " $\gg$ " implies "much greater than".

In the formulated model, the notion of using *pre-emptive priorities* is that the goals which are at  $r$ th priority level  $P_r$  are preferred most to achieve the corresponding aspired levels before taking the achievement problem of goals included at next lower priority level  $P_{r+1}$ .

Now, to design the model of a CM problem, it is worth noting that objectives and some system constraints are with nonlinear characteristics. To avoid computational complexity in Awerbuch et al. (1976) with nonlinearity in model goals and constraints as well as to overcome the burden of hand calculations for linearization of them using approximation technique in Pal et al. (2009), GA as a goal satisfier in Deb (2002) for multiobjective decision analysis is considered for searching solution of the problem. The GA computational scheme is presented in the section 3.

### 3. GA Computational scheme for CM problem

The three probabilistically defined operators in Goldberg (1989): *selection*, *crossover* and *mutation* are used to generate new population (i.e., new solution candidates) in the GA scheme to search solution. The real-value coded chromosomes are considered to perform operations with GA in random fashion. To evaluate a function, say  $Eval(E)_v$ , the fitness score of a chromosome, say  $v$ , according to

A fuzzy goal programming method to solve congestion management problem using genetic... maximization or minimization of an objective function defined by decision maker (DM) in the decision making context. In the proposed MODM model, since  $Eval(E)_v$  is a single-objective linear program, roulette-wheel selection, arithmetic crossover and uniform mutation are adapted to search decision of the problem.

The algorithmic steps of GA computational process are described in the following section 3.1.

### 3.1. GA algorithm

*Step 1. Representation and initialization.*

Let  $E$  denote the double vector representation of chromosome in a population as  $E = (x_1, x_2, \dots, x_n)$ . The population size is defined by  $pop\_size$ , and  $pop\_size$  chromosomes are randomly initialized in the domain of searching solution.

*Step 2. Fitness function.*

The fitness value of each chromosome is judged by the value of an objective function. The fitness function is defined as:

$$Eval(E_r)_v = (Z_r)_v = \left( \sum_{k=1}^K (w_{rk}^- d_{rk}^-) \right)_v, v = 1, 2, 3, \dots, pop\ size \quad (7)$$

where  $(Z_r)_v$  is achievement function  $(Z)$  in (4) for measuring the fitness value of  $v$ th chromosome, when attainments of goals included at  $r$ th priority level  $P_r$  is considered.

The best value of a chromosome is determined as

$$E^* = \min \{ Eval(E)_v \mid v = 1, 2, \dots, pop\ size \} \quad (8)$$

in course of searching minimum value of achievement function.

*Step 3. Selection Stage.*

The simple roulette-wheel scheme is employed for selection of two parents for mating purpose in solution search process.

*Step 4. Crossover Stage.*

The probability of crossover is defined by parameter  $p_c$ . The single-point crossover in Goldberg (1989) is applied here with a view to obtaining offspring that always satisfy linear constraints set. A chromosome is selected as a parent, if for a random number  $r \in [0, 1], r < p_c$  is satisfied.

For example, if two parents  $E_1, E_2 \in S$  are selected, then the arithmetic crossover is defined as:  $E_1^1 = \alpha_1 E_1 + \alpha_2 E_2, E_2^1 = \alpha_2 E_1 + \alpha_1 E_2$ , for generating two offspring  $E_1^1$  and  $E_2^1$ , where  $\alpha_1, \alpha_2 \geq 0$  with  $\alpha_1 + \alpha_2 = 1, E_1^1, E_2^1 \in S$ .

*Step 5. Mutation.*

A parameter  $p_m$  is defined as the probability of mutation. The mutation operation is made uniformly, where for a random number  $r \in [0, 1], r < p_m$ .

*Step 6. Termination.*

The solution search process terminates when best decision for a chromosome is received at a certain generation number in decision making premises.

The pseudo code of the GA is as follows:

Initialize population of chromosomes  $E(x)$   
 Evaluate the initialized population by computing its fitness measure  
 While not termination criteria do  
 $x := x + 1$   
 Select  $E(x+1)$  from  $E(x)$   
 Crossover  $E(x+1)$   
 Mutate  $E(x+1)$   
 Evaluate  $E(x+1)$   
 End While

Now, formulation of FGP model of CM problem is discussed in the section 4.

#### 4. CM problem Formulation

The various objectives that are inherently associated with a CM problem are defined as follows.

##### 4.1 Defining the objective functions

(a) "Overload alleviation" function.

In decision premises, the alleviation of overload on a transmission line is essentially needed to ensure security and stability of system, and thereby taking preventing measure against happening of system outage. Here, transmission line overload can be alleviated by line switching, generation rescheduling and load shedding.

The alleviation of overload in the system takes the form:

$$F_1 = \sum_{i=1}^{NL} (S_i - S_i^{\max})^2 \tag{9}$$

where,  $F_1$  represents cumulative overload,  $NL$  is number of overloaded lines, and where  $S_i$  and  $S_i^{\max}$  be the MVA flow and MVA capacity of line  $i$  in power supply system, respectively. Also, square form of objective is made to avoid masking effect.

(b) Operational cost function.

In this context, the total incurring cost for thermal power plant operation and which is associated with CM problem can be expressed as sum of the fuel cost and cost of load shedding. The total operational cost function is expressed as:

$$F_2 = \sum_{i=1}^{NG} (a_i + b_i P_{Gi} + c_i P_{Gi}^2) + \sum_{k=1}^{PL} (a'_k + b'_k L_{shd,k} + c'_k L_{shd,k}^2) \tag{10}$$

where  $F_2$  denotes total operating cost,  $NG$  be the number of participating generators,  $PL$  is used to represent number of associated loads,  $P_{Gi}$  is generation of power from  $i$ th generator,  $L_{shd,k}$  is amount of load shedding at bus  $k$ , and where  $a_i, b_i, c_i$  are cost coefficients of objective associated with generation of power from generator  $G_i$ , and  $a'_k, b'_k, c'_k$  are cost coefficients of objective associated with load shedding at bus  $k$ .

(c) Power-loss function.

A certain function called real power-loss function which is inherent to a power transmission line and directly affect the ability to transfer power. The mathematical

A fuzzy goal programming method to solve congestion management problem using genetic... expression of real power-loss function,  $F_3$  (MW) can be defined as in Talukdar et al. (2005):

$$F_3 = \sum_{i,j=1}^{TL} g_l [V_i^2 + V_j^2 - 2V_i V_j \cos(\delta_i - \delta_j)] \quad (11)$$

where  $TL$  represents total transmission lines,  $g_l$  be the conductance of  $l$ th line,  $V_i$  and  $V_j$  are voltage magnitudes,  $\delta_i$  and  $\delta_j$  are voltage phase angles at the end buses  $i$  and  $j$  of  $l$ th line, respectively, of the system, where 'cos' designates *cosine* function.

#### 4.2. Definitions of system constraints

The constraints on the power generation system r are as follows:

a) *Power balance constraints.*

The power balance constraints appear as:

$$P_{Gi} - P_{Di} - V_i \sum_{j=1}^H V_j [g_{ij} \cos(\delta_i - \delta_j) + b_{ij} \sin(\delta_i - \delta_j)] = 0$$

$$Q_{Gi} - Q_{Di} - V_i \sum_{j=1}^H V_j [g_{ij} \sin(\delta_i - \delta_j) + b_{ij} \cos(\delta_i - \delta_j)] = 0 \quad (12)$$

where  $H$  be the number of buses,  $P_{Gi}$  and  $Q_{Gi}$  are real- and reactive-power of the generator connected to  $i$ th bus, respectively, and where  $P_{Di}$  and  $Q_{Di}$  be real- and reactive-power of the load connected to  $i$ th bus, respectively,  $g_{ij}$  and  $b_{ij}$  indicate transfer conductance and susceptance between bus  $i$  and bus  $j$ , respectively,  $\delta_i$  and  $\delta_j$  are bus voltage angles of buses  $i$  and  $j$ , respectively.

b) *Determining the Generation capacity & voltage constraint.*

Similar to conventional power generation and dispatch system, constraints on power generation and voltage appear as:

$$P_{G_i}^{\min} \leq P_{G_i} \leq P_{G_i}^{\max},$$

$$Q_{G_i}^{\min} \leq Q_{G_i} \leq Q_{G_i}^{\max}, \quad (13)$$

$$V_i^{\min} \leq V_i \leq V_i^{\max}; \quad i = 1, 2, \dots, N.$$

Now, to show the effective use of the proposed approach, an example is considered in the section 5.

### 5. Case example

The IEEE 30-bus 6-generator test system Talukdar et al. (2005) is addressed to present the effectiveness of the method. The diagram of the system depicted in Figure 3 below.

The diagram shows that the system is with 6 generators, 41 lines and 30 buses. The total demand on 21 load buses is 283.4 MW.



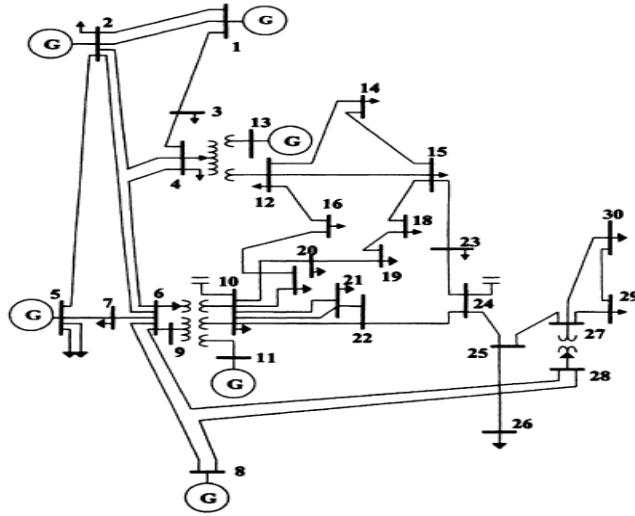

**Figure 3.** Diagram of IEEE 30-bus test system

The model data were collected from the studies (Talukdar et al., 2005; Hazra & Sinha, 2007) made previously. The cost-coefficients of power generation and that of load shedding are presented in the Table 1 and Table 2, respectively.

**Table 1.** Power generation cost –coefficient data

Generator Type ( $T_i$ )	Maximum gen capacity (MW)	A	b	c
T <sub>1</sub>	< 25	0.0	2025.00	1.500
T <sub>2</sub>	50	0.0	1875.00	1.425
T <sub>3</sub>	100	0.0	1800.00	1.350
T <sub>4</sub>	200	0.0	1650.00	1.250
T <sub>5</sub>	250	0.0	1575.00	1.500
T <sub>6</sub>	300	0.0	1575.00	1.250
T <sub>7</sub>	350	0.0	1500.00	1.350
T <sub>8</sub>	400	0.0	1500.00	1.250
T <sub>9</sub>	500	0.0	1200.00	1.500
T <sub>10</sub>	> 500	0.0	1200.00	1.000

**Table 2.** Load shedding cost-coefficient data

Load in a bus (MW)	$a'_k$	$b'_k$	$c'_k$
<=10	0.0	1200	1.00
<=20	0.0	1200	1.50
<=30	0.0	1500	1.25
<=40	0.0	1500	1.35
<=50	0.0	1575	1.25
<=60	0.0	1575	1.5
<=75	0.0	1650	1.25
<=100	0.0	1800	1.35
<=125	0.0	1875	1.425
>125	0.0	2025	1.5

The data associated with transmission lines and loads at buses are presented in the Table 3 and Table 4, respectively.

**Table 3.** Transmission-line data

Line No.	From Bus No.	To Bus No.	Line Impedance		Line No.	From Bus No.	To Bus No.	Line Impedance	
			R(p.u.)	X(p.u.)				R(p.u.)	X(p.u.)
1	1	2	0.0192	0.0575	22	15	18	0.1070	0.2185
2	1	3	0.0452	0.1852	23	18	19	0.0639	0.1292
3	2	4	0.0570	0.1737	24	19	20	0.0340	0.0680
4	3	4	0.0132	0.0379	25	10	20	0.0936	0.2090
5	2	5	0.0472	0.1983	26	10	17	0.0324	0.0845
6	2	6	0.0581	0.1763	27	10	21	0.0348	0.0749
7	4	6	0.0119	0.0414	28	10	22	0.0727	0.1499
8	5	7	0.0460	0.1160	29	21	22	0.0116	0.0236
9	6	7	0.0267	0.0820	30	15	23	0.1000	0.2020
10	6	8	0.0120	0.0420	31	22	24	0.1150	0.1790
11	6	9	0.0000	0.2080	32	23	24	0.1320	0.2700
12	6	10	0.0000	0.5560	33	24	25	0.1885	0.3292
13	9	11	0.0000	0.2080	34	25	26	0.2544	0.3800
14	9	10	0.0000	0.1100	35	25	27	0.1093	0.2087
15	4	12	0.0000	0.2560	36	28	27	0.000	0.3960
16	12	13	0.0000	0.1400	37	27	29	0.2198	0.4153
17	12	14	0.1231	0.2559	38	27	30	0.3202	0.6027
18	12	15	0.0662	0.1304	39	29	30	0.2399	0.4533
19	12	16	0.0945	0.1987	40	8	28	0.6360	0.2000
20	14	15	0.2210	0.1997	41	6	28	0.0169	0.0599
21	16	17	0.0824	0.1932					

**Table 4.** Bus-load data

Bus No.	Load		Bus No.	Load	
	P(p.u.)	Q(p.u.)		P(p.u.)	Q(p.u.)
1	0.000	0.000	16	0.035	0.018
2	0.217	0.127	17	0.090	0.058
3	0.024	0.012	18	0.032	0.009
4	0.076	0.016	19	0.095	0.034
5	0.942	0.190	20	0.022	0.007
6	0.000	0.000	21	0.175	0.112
7	0.228	0.109	22	0.000	0.000
8	0.300	0.300	23	0.032	0.016
9	0.000	0.000	24	0.087	0.016
10	0.058	0.020	25	0.000	0.000
11	0.000	0.000	26	0.035	0.023
12	0.112	0.075	27	0.000	0.000
13	0.000	0.000	28	0.000	0.000
14	0.062	0.016	29	0.024	0.009
15	0.082	0.025	30	0.106	0.019

Table 5 exhibits various simulation runs which were carried out in the test system.

**Table 5.** Simulation runs

Run	Different simulation Cases
1	Overload simulation with reduction of capacity of line 1-2 from 130 MW to 50 MW.
2	Overload simulation with reduction of capacity of line 1-3 and 2-4 from 130 MW to 50 MW and 65 MW to 15 MW.
3	Overload simulation for outage of unit 3 at bus 5 and with reduction of capacity of line 2-5 from 130 MW to 50 MW.

In this case, the Optimization Toolbox under MATLAB (MATLAB R2010a) has been employed to conduct the experiments by employing GA at different stages for program evaluation. The computational environment is Intel Pentium IV with 2.66 GHz. Clock-pulse and 3 GB RAM. In the solution search process, initial population= 50; Roulette-Wheel selection; Single-point crossover with probability= 0.8; Mutation probability= 0.07 and Maximum generation number= 100 are taken into account for exploration and exploitation of search space in the domain of interest.

Then, following the procedure and fitting the data presented in Tables 1 - 5, the membership goals can be obtained by addressing the second goal expression in (4).

The executable FGP models for individual three simulation runs under a priority structure considered for the system are presented as follows.

*Run-1: Simulation of system under overload by reducing capacity of line 1-2 from 130 MW to 50 MW*

The model appears as

Find  $(S_{1-2}, P_{G_i}) \{i = 1, 2, 5, 8, 11, 13\}$  so as to:

A fuzzy goal programming method to solve congestion management problem using genetic...

$$\text{Minimize } Z = \left[ P_1 \left( \frac{1}{2.50} \right) d_1^-, P_2 \left\{ \left( \frac{1}{27942} \right) d_2^- + \left( \frac{1}{2} \right) d_3^- \right\} \right]$$

and satisfy

$$\mu_{F_1} : [\{3.0 - (S_{1-2} - 50)^2\} / (3.0 - 0.5)] + d_1^- - d_1^+ = 1,$$

$$\mu_{F_2} : [\{547942 - (1650P_1 + 1.25P_1^2 + 1875P_2 + 1.425P_2^2 + 1875P_3 + 1.425P_3^2 + 2025P_8 + 1.5P_8^2 + 2025P_{11} + 1.5P_{11}^2 + 2025P_{13} + 1.5P_{13}^2)\} / (537942 - 530000)] + d_2^- - d_2^+ = 1,$$

$$\mu_{F_3} : [(5.50 - F_3) / (5.50 - 3.5)] + d_3^- - d_3^+ = 1,$$

subject to

$$P_{G1} - V_1[V_2\{5.2246 \cos(\delta_1 - \delta_2) - 15.6467 \sin(\delta_1 - \delta_2)\} + V_3\{1.2437 \cos(\delta_1 - \delta_3) - 5.0960 \sin(\delta_1 - \delta_3)\}] = 0 \quad (14)$$

$$P_{G2} - 0.217 - V_2[V_1\{5.2246 \cos(\delta_2 - \delta_1) - 15.6467 \sin(\delta_2 - \delta_1)\} + V_4\{1.7055 \cos(\delta_2 - \delta_4) - 5.1974 \sin(\delta_2 - \delta_4)\} + V_5\{1.1360 \cos(\delta_2 - \delta_5) - 4.7725 \sin(\delta_2 - \delta_5)\} + V_6\{1.6861 \cos(\delta_2 - \delta_6) - 5.1165 \sin(\delta_2 - \delta_6)\}] = 0 \quad (15)$$

$$P_{G5} - 0.942 - V_5[V_2\{1.1360 \cos(\delta_5 - \delta_2) - 4.7725 \sin(\delta_5 - \delta_2)\} + V_7\{2.9540 \cos(\delta_5 - \delta_7) - 7.4493 \sin(\delta_5 - \delta_7)\}] = 0 \quad (16)$$

$$P_{G8} - 0.3 - V_8[V_6\{6.2893 \cos(\delta_8 - \delta_6) - 22.0126 \sin(\delta_8 - \delta_6)\} + V_{28}\{1.4308 \cos(\delta_8 - \delta_{28}) - 0.4499 \sin(\delta_8 - \delta_{28})\}] = 0 \quad (17)$$

$$P_{G13} - V_{13}[V_{12}\{-7.1429 \sin(\delta_{13} - \delta_{12})\}] = 0 \quad (18)$$

$$P_{G11} - V_{11}[V_9\{-4.8077 \sin(\delta_{11} - \delta_9)\}] = 0 \quad (19)$$

$$Q_{G1} - V_1[V_2\{5.2246 \sin(\delta_1 - \delta_2) - 15.6467 \cos(\delta_1 - \delta_2)\} + V_3\{1.2437 \sin(\delta_1 - \delta_3) - 5.0960 \cos(\delta_1 - \delta_3)\}] = 0 \quad (20)$$

$$Q_{G2} - 0.217 - V_2[V_1\{5.2246 \sin(\delta_2 - \delta_1) - 15.6467 \cos(\delta_2 - \delta_1)\} + V_4\{1.7055 \sin(\delta_2 - \delta_4) - 5.1974 \cos(\delta_2 - \delta_4)\} + V_5\{1.1360 \sin(\delta_2 - \delta_5) - 4.7725 \cos(\delta_2 - \delta_5)\} + V_6\{1.6861 \sin(\delta_2 - \delta_6) - 5.1165 \cos(\delta_2 - \delta_6)\}] = 0 \quad (21)$$

$$Q_{G5} - 0.942 - V_5[V_2\{1.1360 \sin(\delta_5 - \delta_2) - 4.7725 \cos(\delta_5 - \delta_2)\} + V_7\{2.9540 \sin(\delta_5 - \delta_7) - 7.4493 \cos(\delta_5 - \delta_7)\}] = 0 \quad (22)$$

$$Q_{G8} - 0.3 - V_8[V_6\{6.2893 \sin(\delta_8 - \delta_6) - 22.0126 \cos(\delta_8 - \delta_6)\} + V_{28}\{1.4308 \sin(\delta_8 - \delta_{28}) - 0.4499 \cos(\delta_8 - \delta_{28})\}] = 0 \quad (23)$$

$$Q_{G11} - V_{11}[V_9\{-4.8077 \cos(\delta_{11} - \delta_9)\}] = 0 \quad (24)$$

$$Q_{G13} - V_{13}[V_{12}\{-7.1429 \cos(\delta_{13} - \delta_{12})\}] = 0 \quad (25)$$

(Equality constraints)

$$50 \leq P_{G_1} \leq 200, 20 \leq P_{G_2} \leq 80, 15 \leq P_{G_5} \leq 50,$$

$$10 \leq P_{G_8} \leq 35, 10 \leq P_{G_{11}} \leq 30, 12 \leq P_{G_{13}} \leq 40 \quad (26)$$

$$\begin{aligned}
 & -20 \leq Q_{G_2} \leq 100, -15 \leq Q_{G_5} \leq 80, -15 \leq Q_{G_8} \leq 60, \\
 & -10 \leq Q_{G_{11}} \leq 50, -15 \leq Q_{G_{13}} \leq 60, \\
 & 0.95 \leq V_{G_i} \leq 1.1, i = 1, 2, 5, 8, 11, 13
 \end{aligned} \tag{27}$$

(Generator constraints)

$$0.85 \leq V_{L_i} \leq 1.05, i = 2, 3, 4, 5, 7, 8, 10, 12, 13, 14, 15, 16, 17, 18, 19, 20, 21, 23, 24, 26, 29, 30$$

(Load-bus voltage constraint)

Run-2: Simulation of system under overload by reducing capacity of line 1-3 and 2-4 from 130 MW to 50 MW and 65 MW to 15 MW

In this case, the executable model is found as:

Find  $(S_i, P_{Gi})$  so as to:

$$\text{Minimize } Z = \left[ P_1 \left( \frac{1}{15} \right) d_1^-, P_2 \left\{ \left( \frac{1}{21942} \right) d_2^- + \left( \frac{1}{2} \right) d_3^- \right\} \right]$$

and satisfy

$$\mu_{F_1} : [(25 - \{(S_{1-3} - 50)^2 + (S_{2-4} - 15)^2\}) / (25 - 10)] + d_1^- - d_1^+ = 1,$$

$$\mu_{F_2} : [(551942 - (1650P_1 + 1.25P_1^2 + 1875P_2 + 1.425P_2^2 + 1875P_5 + 1.425P_5^2 + 2025P_8 + 1.5P_8^2 + 2025P_{11} + 1.5P_{11}^2 + 2025P_{13} + 1.5P_{13}^2) / (551942 - 530000)] + d_2^- - d_2^+ = 1,$$

$$\mu_{F_3} : [(6.50 - F_3) / (6.50 - 4.00)] + d_3^- - d_3^+ = 1,$$

subject to the constraints in (14)-(27).

Run-3: Simulation of system under overload with outage of unit 3 at bus 5 and by reducing capacity of line 2-5 from 130 MW to 50 MW

The executable model is obtained as follows.

Find  $(S_i, P_{Gi})$  so as to:

$$\text{Minimize } Z = \left[ P_1 \left( \frac{1}{3} \right) d_1^-, P_2 \left\{ \left( \frac{1}{21942} \right) d_2^- + \left( \frac{1}{1.50} \right) d_3^- \right\} \right]$$

and satisfy

$$\mu_{F_1} : [5 - (S_{2-5} - 50)^2] / (5.00 - 2.00) + d_1^- - d_1^+ = 1,$$

$$\mu_{F_2} : \{(551942 - (1650P_1 + 1.25P_1^2 + 1875P_2 + 1.425P_2^2 + 2025P_8 + 1.5P_8^2 + 2025P_{11} + 1.5P_{11}^2 + 2025P_{13} + 1.5P_{13}^2) / (551942 - 530000)\} + d_2^- - d_2^+ = 1,$$

$$\mu_{F_3} : [(10.00 - F_3) / (10.00 - 8.50)] + d_3^- - d_3^+ = 1,$$

subject to the problem constraints in (14) - (27).

The goal achievement function ( $Z$ ) defined for the three runs actually describes the evaluation function in GA search process for solving the problem.

The evaluation function for determining the fitness of a chromosome is given as:

$$\text{Eval}(E_r)_v = (Z_r)_v = \left( \sum_{k=1}^3 (w_{rk}^- d_{rk}^-) \right)_v, v = 1, 2, 3, \dots, 50; r = 1, 2$$

A fuzzy goal programming method to solve congestion management problem using genetic...

The best value of objective ( $Z^*$ ) for the fittest chromosome is determined as:

$$E^* = \min\{Eval(E)_v \mid v=1,2,\dots,50\}.$$

The solutions obtained from the three runs of the test system are presented in the Table 6.

**Table 6.** Solution achievements under different runs

Run	Overload-condition			Solution			
	Line/Unit	MVA Flow	MVA Capacity	MVA Flow	Power-loss (MW)	Png (ng=1,2,5,8,11,13)	Cost (Rs/ hr)
1	1-2	61.25	50	49.55	3.78	(82.27, 58.59, 50.00, 35.00, 30.00, 31.32)	536633.75
2	1-3 and 2-4	35.44	50	35.50	4.50	(112.44, 20.46, 50.00, 35.00, 30.00, 40.00)	538219.96
	2-5 and Out of Unit 3	20.30	15	14.95		(122.22, 31.24, 0.00, 35.00, 30.00, 40.00)	
3	Out of Unit 3	40.89	50	48.12	8.76	(31.2 MW Load-Shaded)	550064.38

It is clear from the results that the decision is a satisfactory one from the view point of proper management of MVA flow with incurring of minimum operational cost of the power plant in imprecise environment.

To show the effective use of the approach, a performance comparison is made in the section 6.

## 6. Performance comparison

The PSO technique in Hazra and Sinha (2007) is considered for a solution comparison. The resulting decision is presented in the Table 7.

**Table 7.** Results of three simulation cases under PSO technique

Case	Overloaded Condition		Solution	
	Line/Unit	MVA Capacity	MVA Flow	Cost (Rs/ hr)
1	Line 1-2	50	49.16	541171
2	Line 1-3 and Line 2-4	50	12.31	542465
	Line 2-5	15	14.99	
3	and Unit 3 Out	50	49.88	565979

The MVA flow and total incurring cost of the CM problem under the proposed model and PSO technique are diagrammatically presented in Figure 4 and Figure 5, respectively.

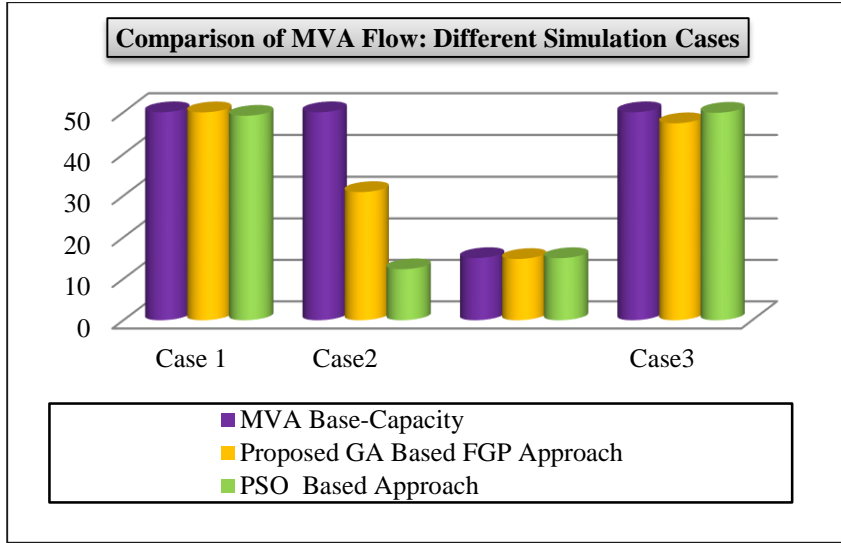

**Figure 4.** Graphical representation of MVA flow comparison

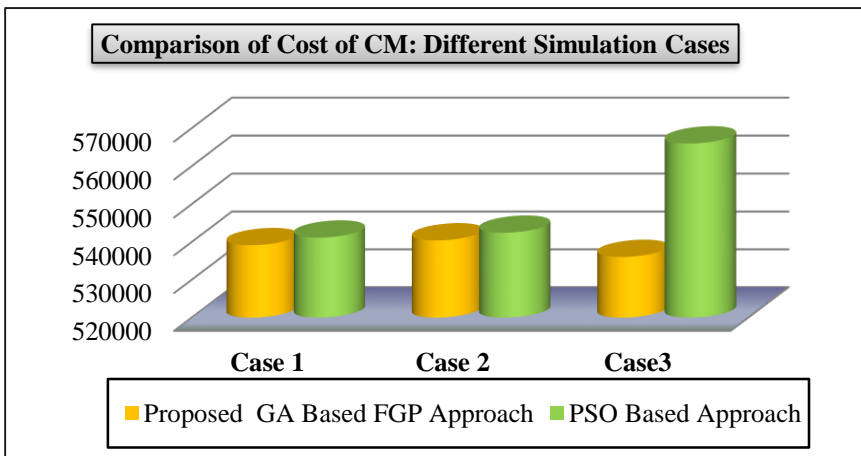

**Figure 5.** Graphical representation of cost comparison

The result comparisons show that the proposed approach is superior over the PSO to arrive at appropriate decision in imprecise environment.

## 7. Conclusion

The main merit of the method presented here is that the fuzzy characteristics regarding attainment of objectives values are preserved there in all possible instances of executing the model of the CM problem. Again, computational complexity arising out of the nonlinearity in the goals and constraints associated with the model can easily be avoided here with the use of GA based solution search approach for solving problems in imprecise environment. The proposed method is also advantageous in the

A fuzzy goal programming method to solve congestion management problem using genetic... sense that here a multi-objective optimization problem can be converted into a goal oriented single objective optimization problem for achieving a compromise solution in the decision making horizon. Further, the proposed approach is flexible enough to accommodate different other restrictions as and when needed for CM in electric power transmission system. However, the use of interval data in Pal (2018), instead of considering fuzziness of model parameters, towards promoting CM performances and thereby improving quality of solution is an interesting alley of research for optimization of a power supply problem.

**Acknowledgments:** The authors would like to thank anonymous Reviewers for useful comments and suggestions to improve the quality and clarity of presentation of the paper.

**Author Contributions:** Each author has participated and contributed sufficiently to take public responsibility for appropriate portions of the content.

**Funding:** This research received no external funding.

**Conflicts of Interest:** The authors declare that they have no known competing financial interests or personal relationships that could have appeared to influence the work reported in this paper.

## References

- Awerbuch, S., Ecker, J. G., & Wallace, W. A. (1976). Note—A Note: Hidden Nonlinearities in the Application of Goal Programming. *Management Science*, 22(8), 918-920.
- Balaraman, S., & Kamaraj, N. (2010). Congestion management using hybrid particle swarm optimization technique. *International Journal of Swarm Intelligence Research*, 1(3), 51-66.
- Bhattacharya, K., Bollen, M. H., & Daalder, J. E. (2012). *Operation of restructured power systems*. Springer Science & Business Media.
- Chung, H. M., Su, C. L., & Wen, C. K. (2015). Dispatch of generation and demand side response in regional grids. In 2015 IEEE 15th International Conference on Environment and Electrical Engineering (EEEIC) (pp. 482-486). IEEE.
- Deb, K. (2002). *Multiobjective optimization using evolutionary algorithm*. United States: John Wiley and Sons Ltd.
- Dubois, D. (1987). Linear programming with fuzzy data. *The Analysis of Fuzzy Information (III)*, 3, 241-263.
- Dutta, S., & Singh, S. P. (2008). Optimal rescheduling of generators for congestion management based on particle swarm optimization. *IEEE transactions on Power Systems*, 23(4), 1560-1569.
- El-Abiad, A. H., & Stagg, G. W. (1962). Automatic evaluation of power system performance-effects of line and transformer outages. *Transactions of the American Institute of Electrical Engineers. Part III: Power Apparatus and Systems*, 81(3), 712-715.



Emami, H., & Sadri, J. A. (2012). Congestion management of transmission lines in the market environment. *International Research Journal of Applied and Basic Sciences*, 3(12), 2572-2580.

Fang, R. S., & David, A. K. (1999). An integrated congestion management strategy for real-time system operation. *IEEE Power Engineering Review*, 19(5), 52-54.

Finney, J. D., Othman, H. A., & Rutz, W. L. (1997). Evaluating transmission congestion constraints in system planning. *IEEE Transactions on Power Systems*, 12(3), 1143-1150.

Goldberg, D. E. (1989). *Genetic algorithms in search, optimization, and machine learning*. Addison-Wesley, Reading.

Hazra, J., & Sinha, A. K. (2007). Congestion management using multiobjective particle swarm optimization. *IEEE Transactions on Power Systems*, 22(4), 1726-1734.

Hazra, J., & Sinha, A. K. (2009). Identification of catastrophic failures in power system using pattern recognition and fuzzy estimation. *IEEE Transactions on Power Systems*, 24(1), 378-387.

Kumar, A., Srivastava, S. C., & Singh, S. N. (2004). A zonal congestion management approach using real and reactive power rescheduling. *IEEE transactions on power systems*, 19(1), 554-562.

Kumar, J. V., Kumar, D. V., & Edukondalu, K. (2013). Strategic bidding using fuzzy adaptive gravitational search algorithm in a pool based electricity market. *Applied soft computing*, 13(5), 2445-2455.

Lee, K. H. (2002). Optimal siting of TCSC for reducing congestion cost by using shadow prices. *International journal of electrical power & energy systems*, 24(8), 647-653.

Manandur, K. R. C., & Berg, G. J. (1978). Economic shift in electric power generation with line flow constraints. *IEEE Transactions on Power Apparatus and Systems*, (5), 1618-1626.

Medicherla, T. K. P., Billinton, R., & Sachdev, M. S. (1979). Generation rescheduling and load shedding to alleviate line overloads-analysis. *IEEE Transactions on Power Apparatus and Systems*, (6), 1876-1884.

Milano, F., Cañizares, C. A., & Invernizzi, M. (2003). Multiobjective optimization for pricing system security in electricity markets. *IEEE Transactions on power systems*, 18(2), 596-604.

Nappu, M. B., & Arief, A. (2016). Network losses-based economic redispatch for optimal energy pricing in a congested power system. *Energy Procedia*, 100, 311-314.

Pal, B. B. (2018). Interval-valued goal programming method to solve patrol manpower planning problem for road traffic management using genetic algorithm. *Multi-Objective Optimization: Evolutionary to Hybrid Framework*, 79-113.

Pal, B. B., & Chakraborti, D. (2013). Using genetic algorithm for solving quadratic bilevel programming problems via fuzzy goal programming. *International Journal of Applied Management Science*, 5(2), 172-195.

- A fuzzy goal programming method to solve congestion management problem using genetic...
- Pal, B. B., Moitra, B. N., & Maulik, U. (2003). A goal programming procedure for fuzzy multiobjective linear fractional programming problem. *Fuzzy sets and systems*, 139(2), 395-405.
- Pal, B. B., Sen, S., & Kumar, M. (2009, December). A linear approximation approach to chance constrained multiobjective decision making problems. In 2009 First International Conference on Advanced Computing (pp. 70-75). IEEE.
- Rau, N. S. (2000). Transmission loss and congestion cost allocation-an approach based on responsibility. *IEEE Transactions on Power systems*, 15(4), 1401-1409.
- Rodrigues, A. B., & Da Silva, M. G. (2003). Impact of multilateral congestion management on the reliability of power transactions. *International journal of electrical power & energy systems*, 25(2), 113-122.
- Singh, H., Hao, S., & Papalexopoulos, A. (1998). Transmission congestion management in competitive electricity markets. *IEEE Transactions on power systems*, 13(2), 672-680.
- Singh, S. N., & David, A. K. (2000). Towards dynamic security-constrained congestion management in open power market. *IEEE Power Engineering Review*, 20(8), 45-47.
- Talukdar, B. K., Sinha, A. K., Mukhopadhyay, S., & Bose, A. (2005). A computationally simple method for cost-efficient generation rescheduling and load shedding for congestion management. *International Journal of Electrical Power & Energy Systems*, 27(5-6), 379-388.
- Venkaiah, C., & Kumar, D. V. (2011). Fuzzy adaptive bacterial foraging congestion management using sensitivity based optimal active power re-scheduling of generators. *Applied Soft Computing*, 11(8), 4921-4930.
- Verma, K. S., Singh, S. N., & Gupta, H. O. (2001). Location of unified power flow controller for congestion management. *Electric power systems research*, 58(2), 89-96.
- Wang, X., & Song, Y. H. (2000). Advanced real-time congestion management through both pool balancing market and bilateral market. *IEEE Power engineering review*, 20(2), 47-49.
- Yamin, H. Y., & Shahidehpour, S. M. (2003). Transmission congestion and voltage profile management coordination in competitive electricity markets. *International Journal of Electrical Power & Energy Systems*, 25(10), 849-861.
- Zimmermann, H. J. (1987). *Fuzzy sets, decision making, and expert systems* (Vol. 10). Springer Science & Business Media.



© 2019 by the authors. Submitted for possible open access publication under the terms and conditions of the Creative Commons Attribution (CC BY) license (<http://creativecommons.org/licenses/by/4.0/>).